

# MOUNTING INSTRUCTION

## LOOP CORNER #171

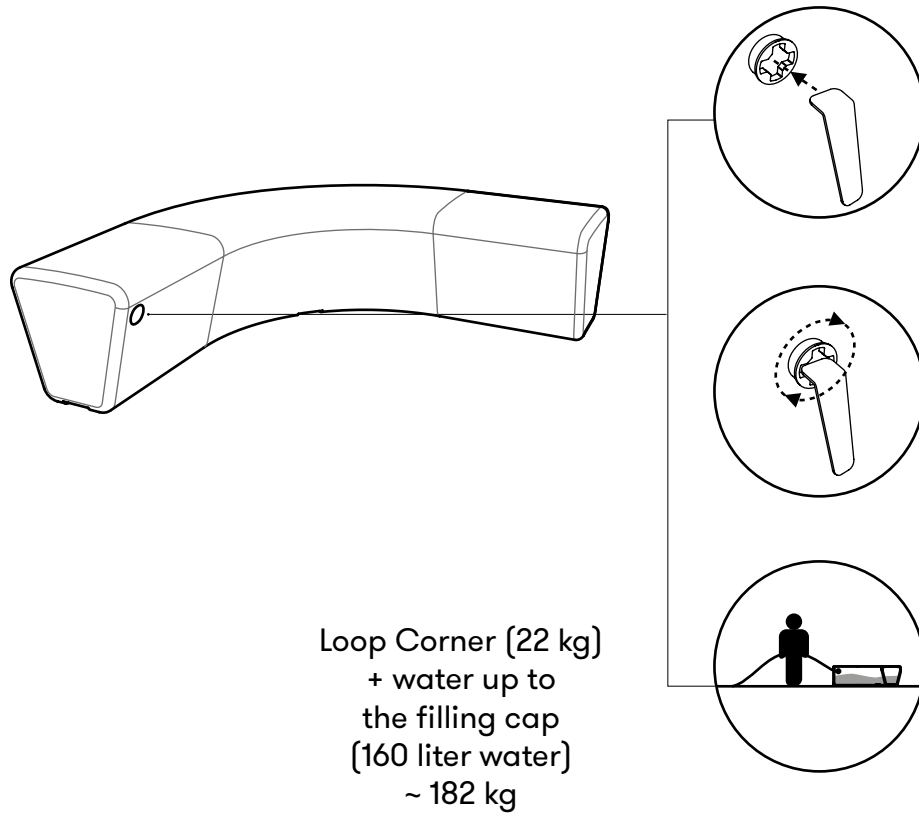

FILLED WITH WATER



FILLED WITH SAND

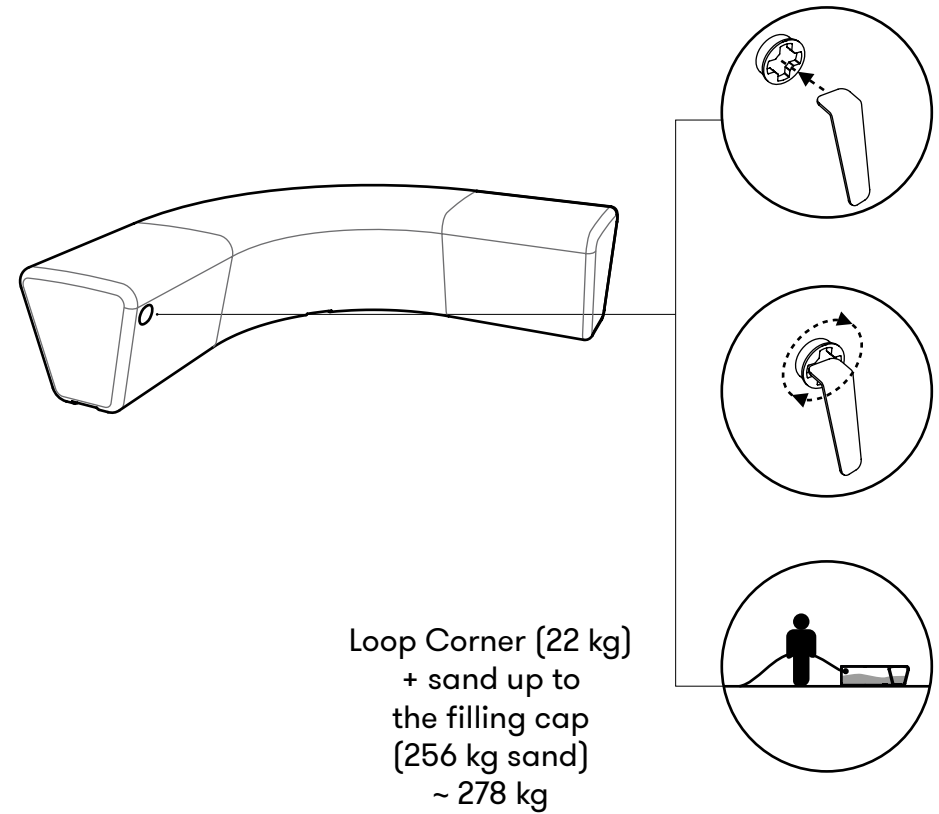

## SAND BLASTING PLASTIC PRODUCTS

If you wish to hire a company to do the job, seek suppliers called **sand blaster**.

If you want to do the job yourself, equipment can be rented by companies supplying the construction industry. Search for **sand blasting equipment**.

Equipment that will be used to fill in the sand:

- 1) Sand, easiest with *fine blowing sand*  
0.3-1.0mm, oven dried
- 2) Sand pot
- 3) Compressor
- 4) Hose, max  $\varnothing$ 50mm

*\*It is recommended to consult professionals as well as instruction manuals on the equipment before it is used.*



1) Sand



2) Sand pot



3) Compressor



4) Hose, max  $\varnothing$ 50mm

### B2 BRACKET FOR GROUND FIXATION

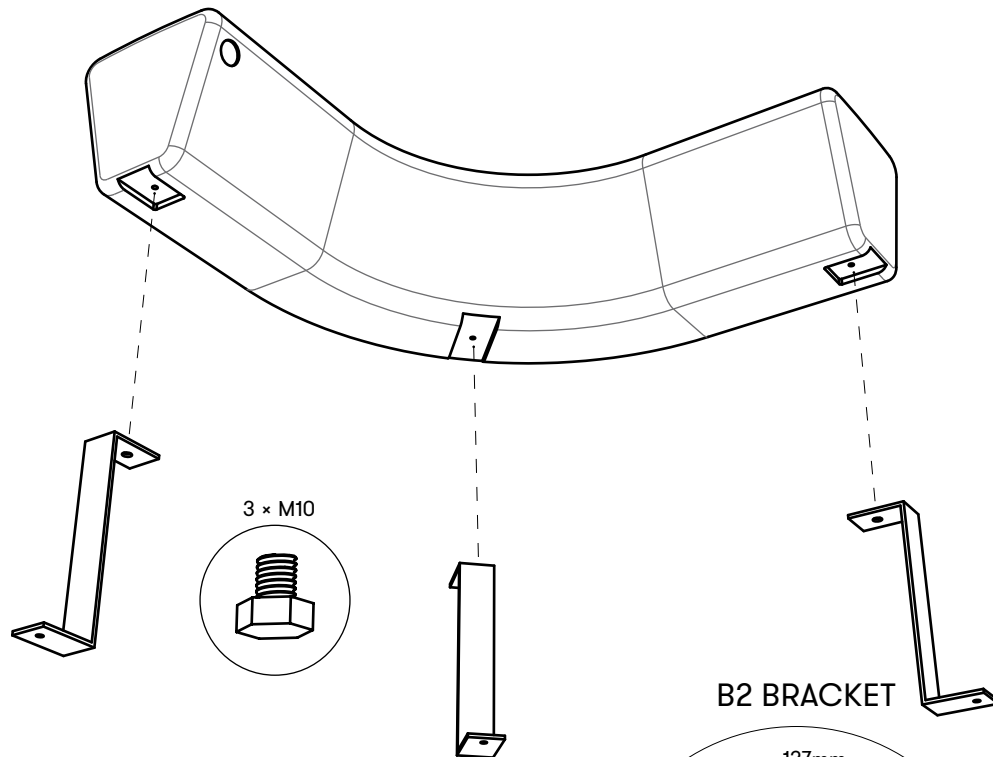

B2 BRACKET

Each bracket is mounted to the bottom of Loop Corner with supplied M10×12 bolts.

Estimate the required number of brackets (1-2) according to local conditions.

### B3 BRACKET FOR SURFACE FIXATION

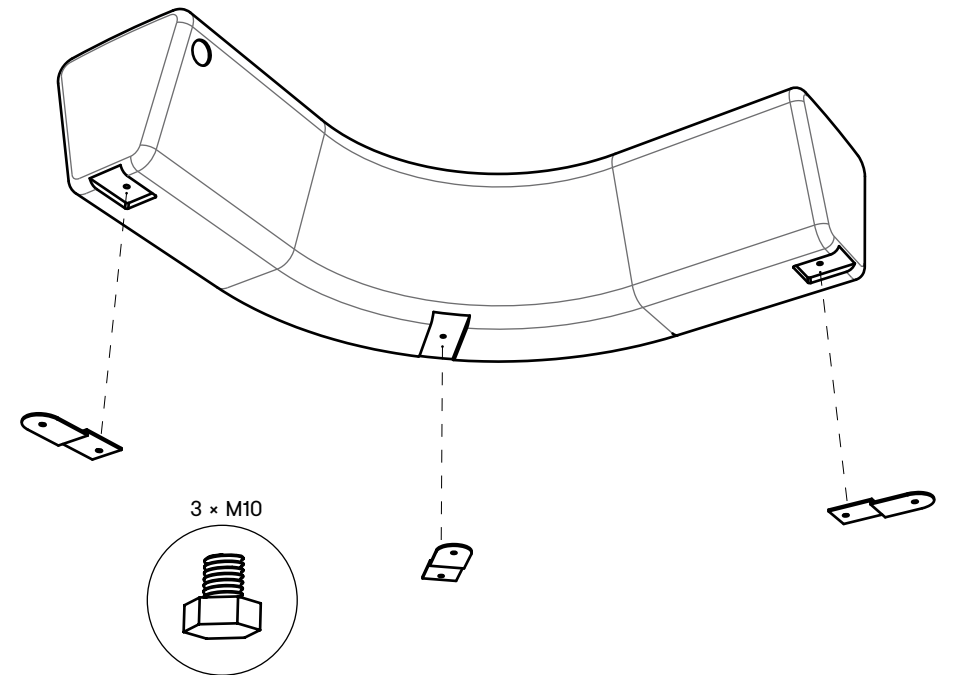

B3 BRACKET

Each bracket is mounted to the bottom of Loop Corner with supplied M10×12 bolts.

Estimate the required number of brackets (1-2) according to local conditions.

### B4 ASSEMBLY BRACKET

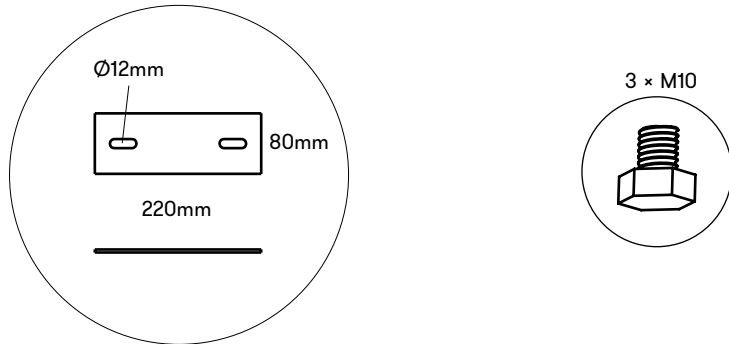

The modules are assembled with adjustable (0-50mm) assembly bracket (B4) at each end of Loop Corner.

The bracket is mounted on the bottom of each Loop Corner with the provided M10×12 bolts.

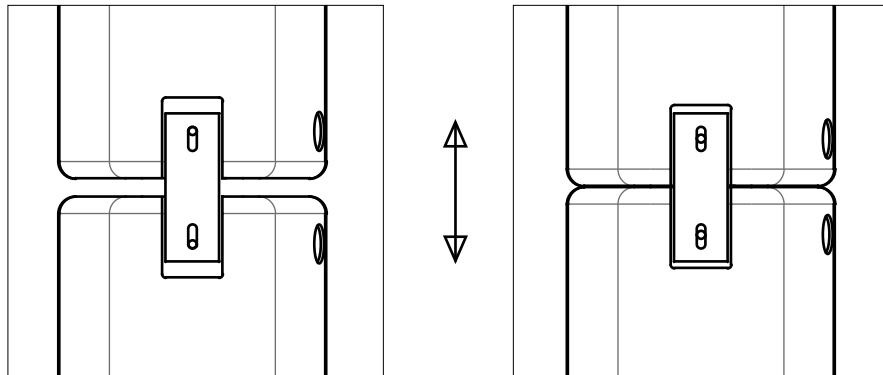

### RUBBER FEET

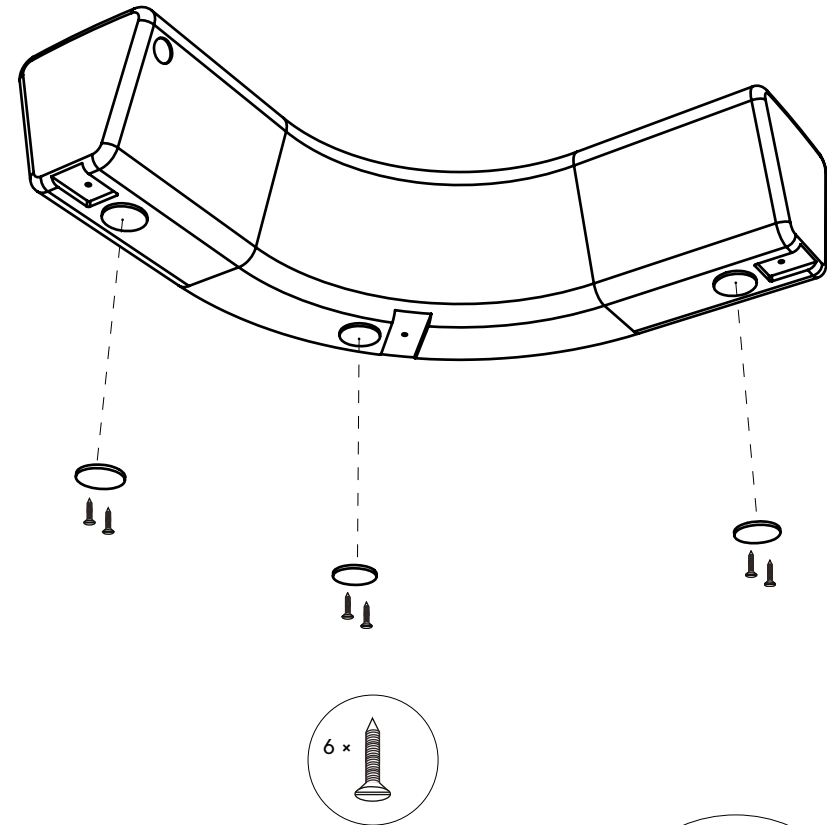

Each rubber foot is mounted with two screws - in total 3 rubber feet are mounted.

**NOTE!** If Loop Corner is filled with water rubber feet are NOT to be mounted with screws but simply placed loosely under Loop Corner.

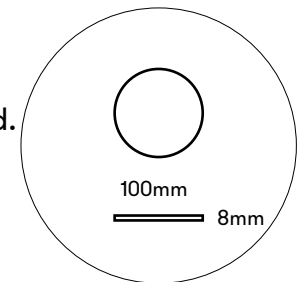

## #209 ARMREST

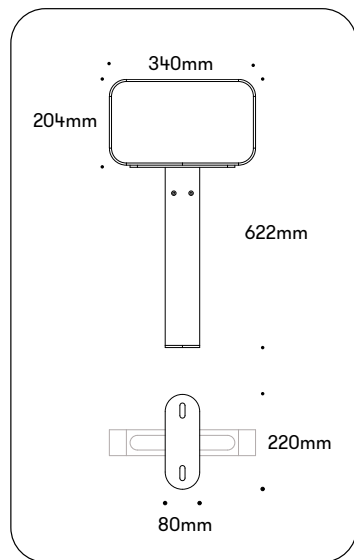
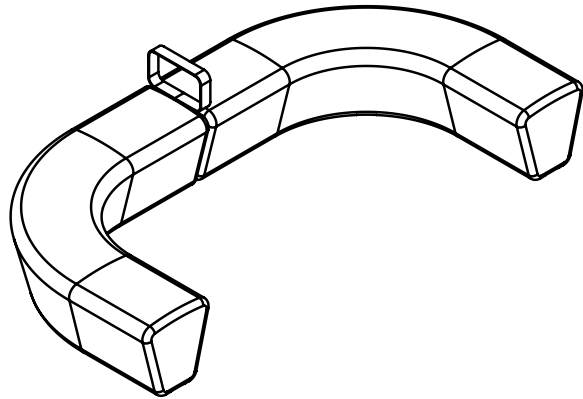

The armrest is placed between 2 modules.

At the same time, the armrest also works as an assembly bracket between 2 modules, which is why B4 brackets are not used.

1. The armrest is first mounted at the bottom of one Corner with the supplied bolts.
2. The armrest is attached to the end of Corner with the supplied 2 self-tapping screws.
3. Finally, mount the second Corner to the bracket.

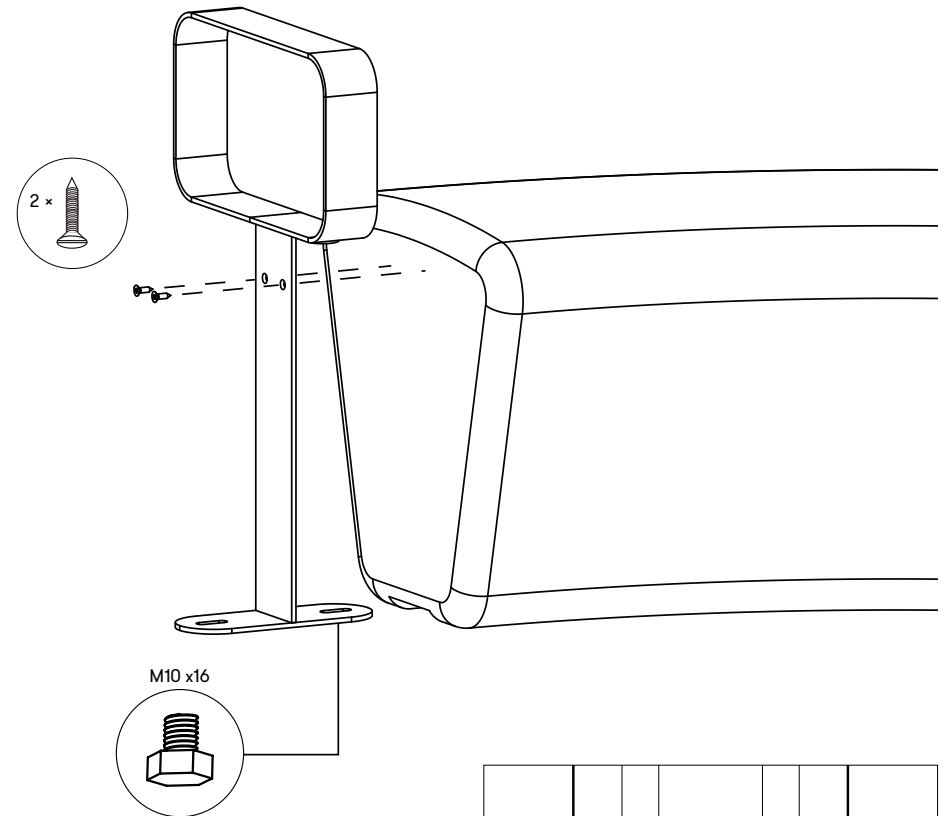

**NOTE!** Hold the two modules close together when the bolts at the bottom are tightened.

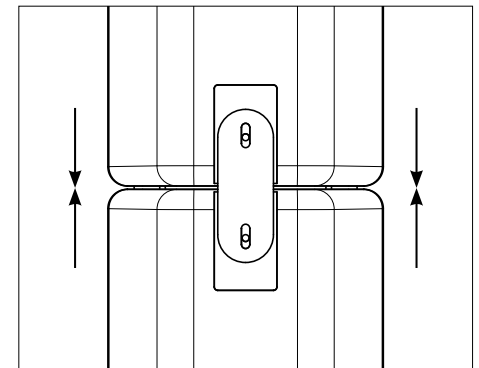

## CLEANING INSTRUCTIONS

Polyethylene can withstand almost all cleaning agents.

The material does not need to be maintained.

Preserves the colours.

A high-pressure cleaner can be used for cleaning the product.

## NON-SLIP SURFACES

Because of the surface treatment of the mould, a rough surface is obtained in the final product. This process increases the friction and thereby makes the surface less slippery.